

## 24-INCH CHARCOAL GRILL

24-INCH HOLZKOHLEGRILL

24-POUCES GRIL À CHARBON

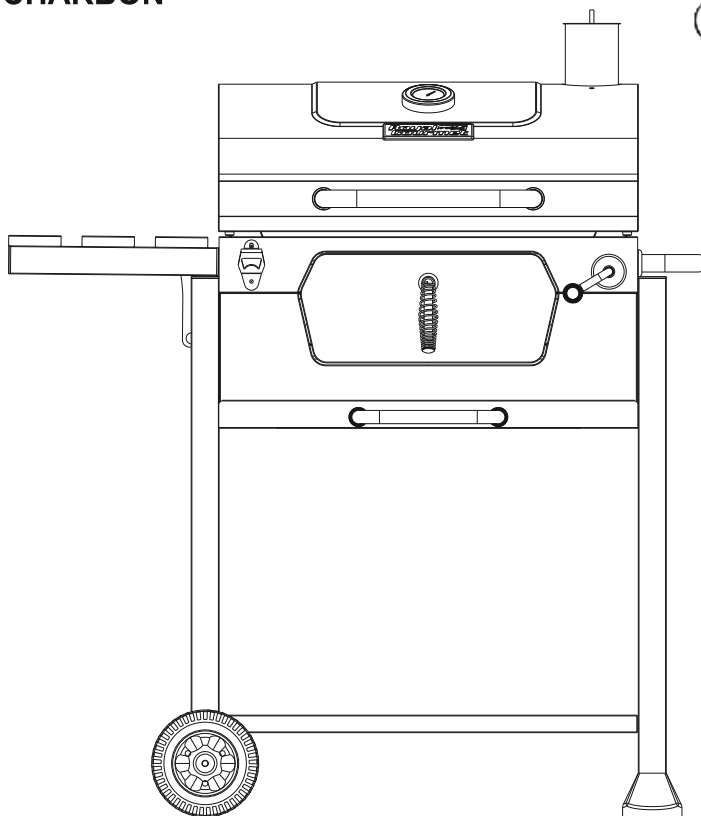

### FOR YOUR SAFETY!

Use outdoors only!  
Read the instructions before assembling and using the appliance.

### ZU IHRER SICHERHEIT!

Verwenden Sie es nur im Freien!  
Lesen Sie die Anleitung, bevor Sie das Gerät zusammenbauen und benutzen.

### POUR VOTRE SÉCURITÉ!

Utilisez uniquement à l'extérieur!  
Lisez les instructions avant d'assembler et d'utiliser l'appareil.

### CONTACT US FIRST!

If you have any questions that are not addressed, please contact us first.

### KONTAKTIEREN SIE UNS ZUERST!

Wenn Sie Fragen haben, die nicht adressiert, kontaktieren Sie uns bitte zuerst.

### CONTACTEZ-NOUS D'ABORD!

Si vous avez des questions qui ne sont pas traitées dans ce manuel de l'utilisateur, contactez-nous d'abord.

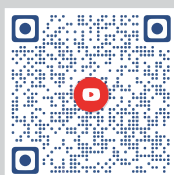
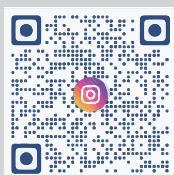

Customer Service / Kundendienst / Service de Clientèle









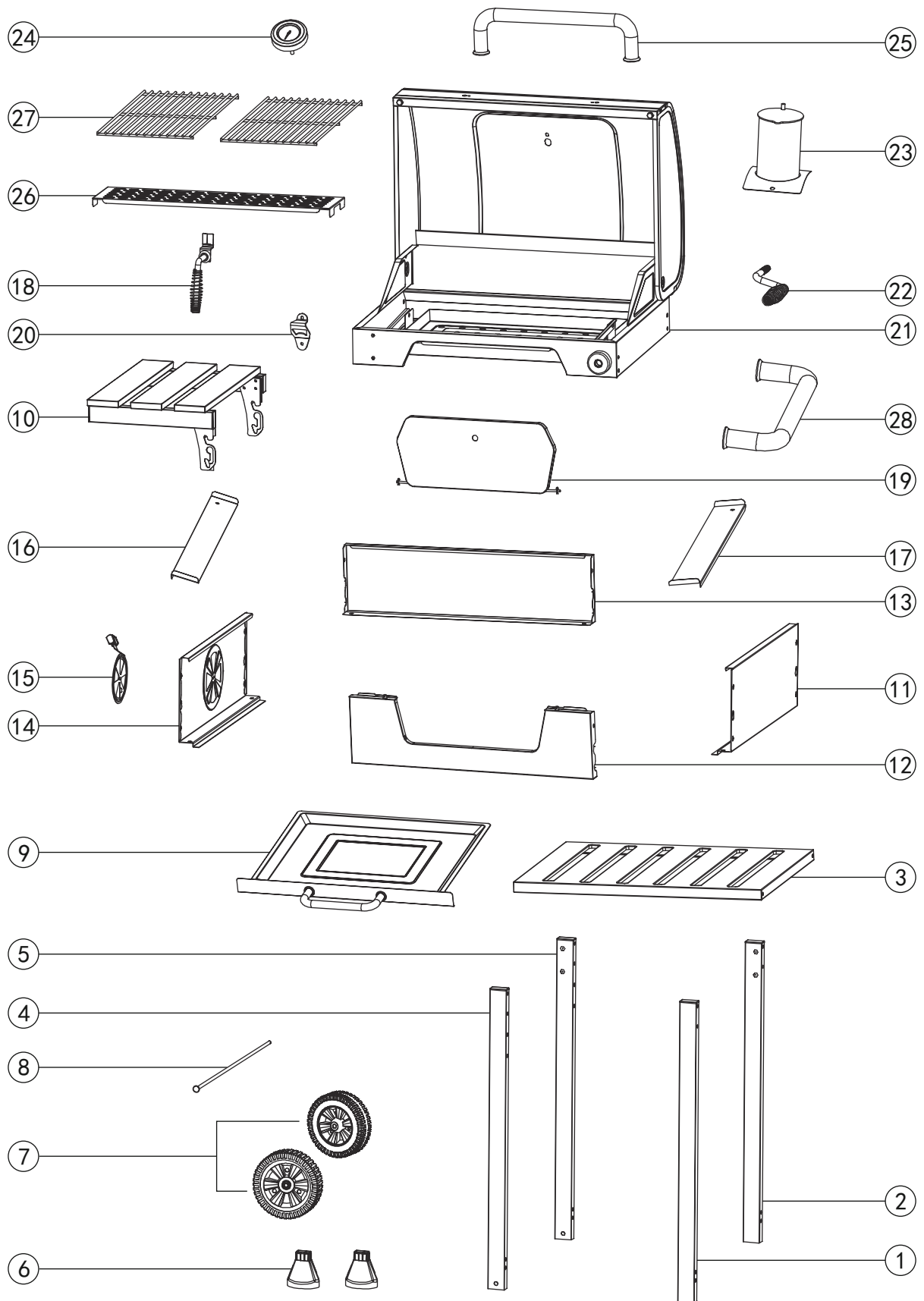



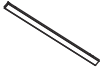

 [service@royalgourmet.eu](mailto:service@royalgourmet.eu)







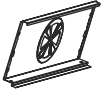

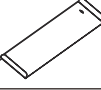
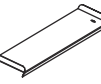

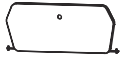
Learn more at / Erfahren Sie mehr unter / Pour en savoir plus:







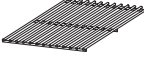





[www.royalgourmet.eu](http://www.royalgourmet.eu)





No. / Nr. / N°	#	QYT / ANZAHL / QTÉ	Description / Beschreibung / Description	Image / Abbild / Image
1	CD1824EJFT GRF01	1	Right front leg Rechtes Vorderbein Pied avant droit	
2	CD1824EJFT GRB01	1	Right back leg Rechtes Hinterbein Pied arrière droit	
3	CD1824EJDB01	1	Bottom shelf Untere Ablage Étagère inférieure	
4	CD1824EJFT GLF01	1	Left front leg Linkes vorderes Bein Pied avant gauche	
5	CD1824EJFT GLB01	1	Left back leg Linkes hinteres Bein Pied arrière gauche	
6	05-JSL-05	2	Leg base Beinbasis Base de pied	
7	05-SLL-04	2	Wheel Rad Roue	
8	06-XZL-1-03A-DY	1	Wheel axle Radachse Essieu de roue	
9	CD1824ELHP- RGG-DS1 04-GBS-2-01- 200-PG	1	Ash tray Aschenlade Bac à cendres	
10	CD1824ET01H	1	Side table Beistelltisch Table d'appoint	
11	CD1824ELCBR02- RGG	1	Right panel Rechte Platte Panneau droit	
12	CD1824ELQB02H- RGG	1	Front panel Frontplatte Panneau avant	
13	CD1824ELHB02H- RGG	1	Rear panel Rückplatte Panneau arrière	
14	CD1824ELCBL02- RGG	1	Left panel Linke Platte Panneau gauche	
15	CYFMP01-SS4 04-SBS-14	1	Damper Klappe Amortisseur	
16	CD1824ELDYPL- RGG	1	Grease deflector (L) Fettabweiser (L) Déflecteur de graisse (G)	
17	CD1824ELDYPR- RGG	1	Grease deflector (R) Fettabweiser (R) Déflecteur de graisse (D)	

No. / Nr. / N°	#	QYT / ANZAHL / QTÉ	Description / Beschreibung / Description	Image / Abbild / Image
18	04-XBS-22-DD1 04-BSZ-25-DD1 04-BSZ-41-DD1 04-BST-41-DD1	1	Door handle Türgriff Poignée de porte	
19	CD1824ELTM- RGG	1	Charcoal access door Holzkohle Zugangstür Porte d'accès au charbon	
20	TY-KPQ01-SS4	1	Bottle opener Flaschenöffner Ouvre-bouteille	
21		1	Main body Hauptgehäuse Corps principal	
22	04-YGL-03-DD1 04-BST-41-DD1	1	Crank handle Handkurbel Manivelle	
23	CYC03H TY-YCGB01	1	Stack Stapel Cheminée	
24	06-WDJ-3-04	1	Thermometer Thermometer Thermomètre	
25	04-GBS-2-25- 300-DH	1	Lid handle Deckelgriff Poignée du couvercle	
26	ELBWW013B- SS4	1	Warming rack Wärmeständer Grille de réchauffement	
27	03-XKW-C-07- D-TC3	2	Cooking grate Grillrost Grille de cuisson	
28	04-GBS-2-28- 400-DH	1	Side handle Seitengriff Poignée d'appoint	

Key / Ref / Réf.	Description / Beschreibung / Description	QTY / ANZAHL / QTÉ	Image / Abbild / Image
A	M5x55	12	
B	M5x10	8	
C	M4x15	4	
D	Split pin Sicherungsstift Goupille fendue	1	
E	Washer Kissen Rondelle	2	
F	M6	2	
G	M6x15	6	
H	M6x20	4	
I	M5	1	
J	M5	1	
K	M4x10	2	
L	M5x12	1	

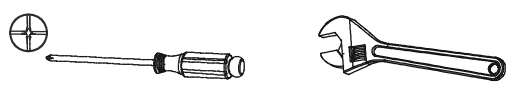
TOOLS REQUIRED / Erforderliche Werkzeuge Für die Montage / OUTILS REQUIS	
Description / Beschreibung / Description	Image / Abbild / Image
Phillips screwdriver Kreuzschraubendreher Tournevis phillips	Wrench Schraubenschlüssel Clé
	

Before beginning assembly, make sure all parts are present. If any parts are missing or damaged, do not attempt to assemble the products. Contact customer service for replacement parts via telephone or email.

- Tools needed (not included): Phillips screwdriver and wrench
- Approximate assembly time: 50 minutes
- Note: 1. The right and left sides of the grill are designed as if you are facing the front of the grill.  
2. Model shown for illustration purpose only, specific please in kind prevail.

Bevor Sie mit der Montage beginnen, stellen Sie sicher, dass alle Teile vorhanden sind. Wenn Teile fehlen oder beschädigt sind, versuchen Sie nicht, die Produkte zusammenzubauen. Kontaktieren Sie den Kundendienst für Ersatzteillieferung via Telefon oder E-Mail.

- Erforderliche Werkzeuge ( nicht mitgeliefert ) : Kreuzschraubendreher und Schraubenschlüssel
- Ungefähre Montagezeit: 50 Minuten
- Hinweis: 1. Die rechte und linke Seite des Grills sind so gestaltet, als ob Sie der Vorderseite des Grills zugewandt wären.  
2. Modell nur zur Veranschaulichung gezeigt, spezifisch bitte in der Art vorherrschend.

Avant de commencer l'assemblage, assurez-vous que toutes les pièces sont présentes. Si des pièces sont manquantes ou endommagées, n'essayez pas d'assembler les produits. Contactez le service de clientèle pour les pièces de rechange par téléphone ou par e-mail.

- Outils nécessaires (non inclus): Tournevis phillips et clé
- Temps nécessaire pour l'assemblage: 50 minutes
- Remarque: 1. Les côtés droit et gauche du gril sont conçus comme si vous faisiez face à l'avant du gril.  
2. Le modèle est présenté à des fins d'illustration uniquement, spécifiques en nature prévalent.

1

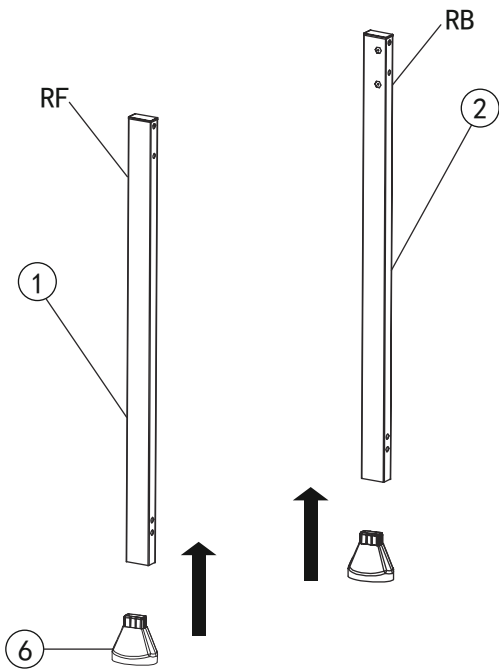

2

A		×2
---	--	----

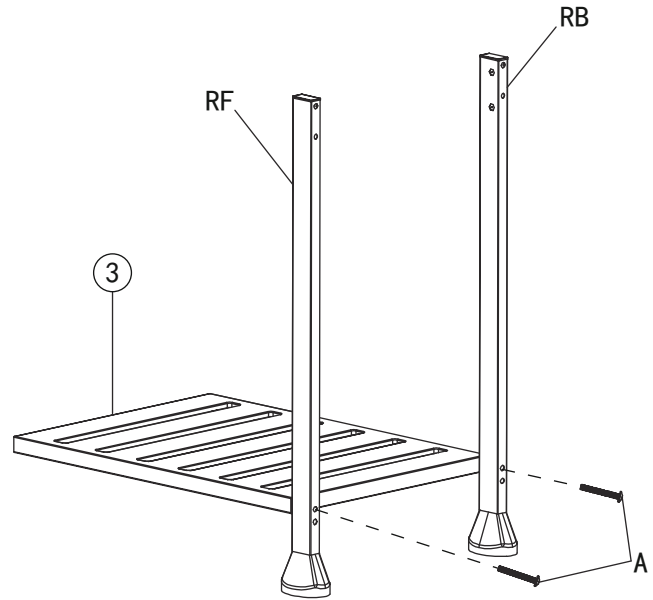

3

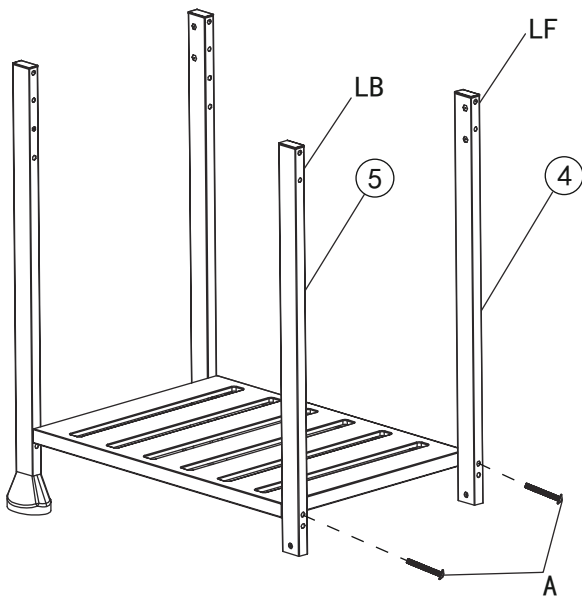

A		×2
---	--	----

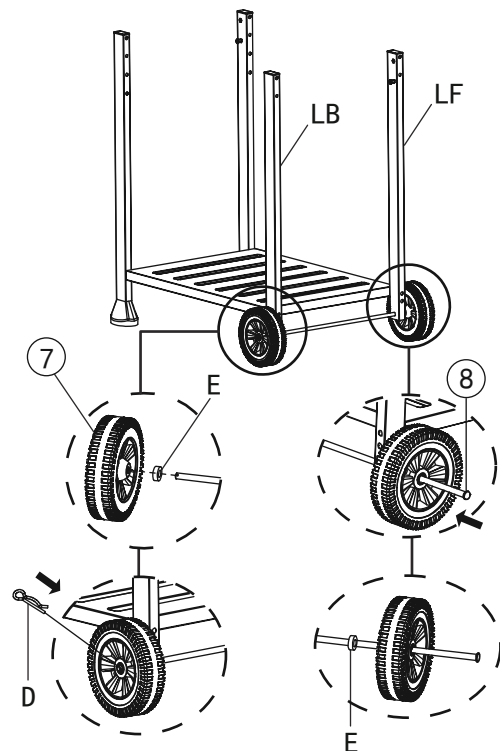

4

D		×1
E		×2



<b>5</b>	I		×1
	J		×1
	L		×1

- Note direction.
- Richtung notieren
- Attention au sens.

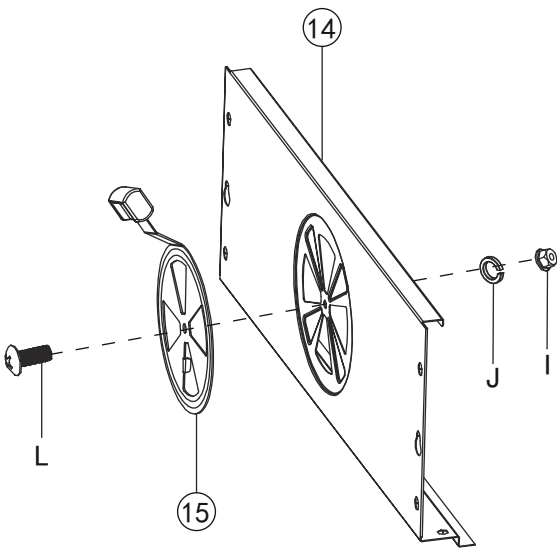

<b>6</b>	B		×4
----------	---	--	----

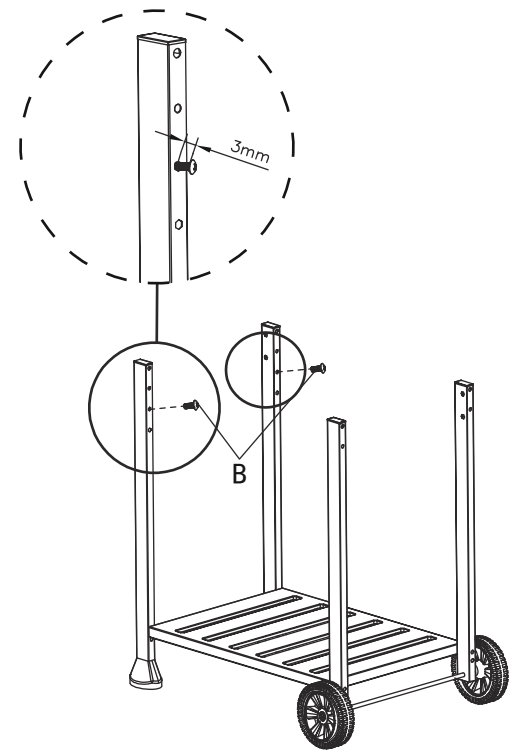

- 7**
- Repeat for the other panel.
  - Wiederholen Sie diesen Vorgang für die andere Platte.
  - Répéter le étape pour l'autre côté.

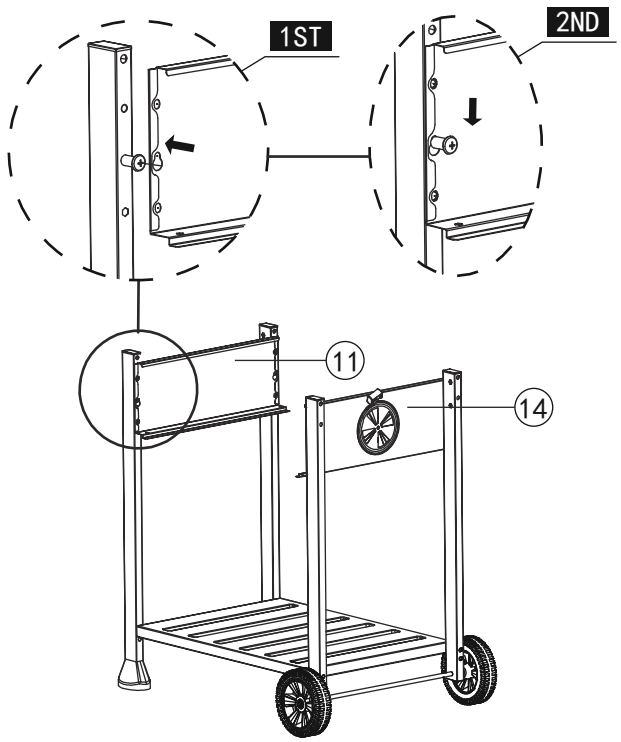

<b>8</b>	B		×4
----------	---	--	----

- Repeat for the other panel.
- Wiederholen Sie diesen Vorgang für die andere Platte.
- Répéter le étape pour l'autre côté.

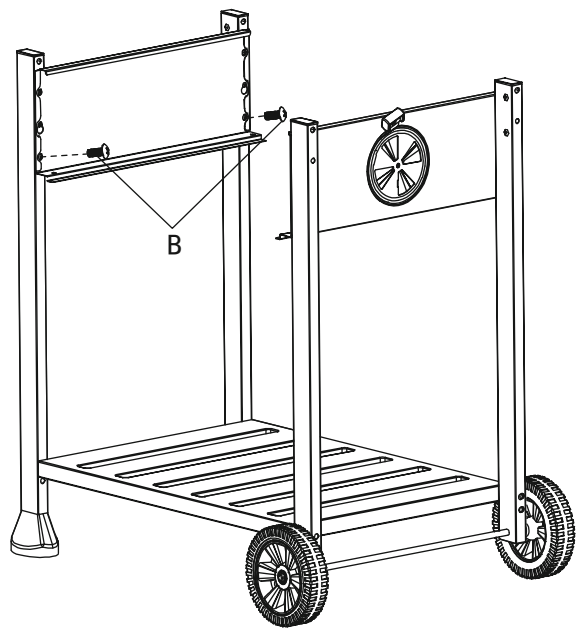



9 A ⊕  x4

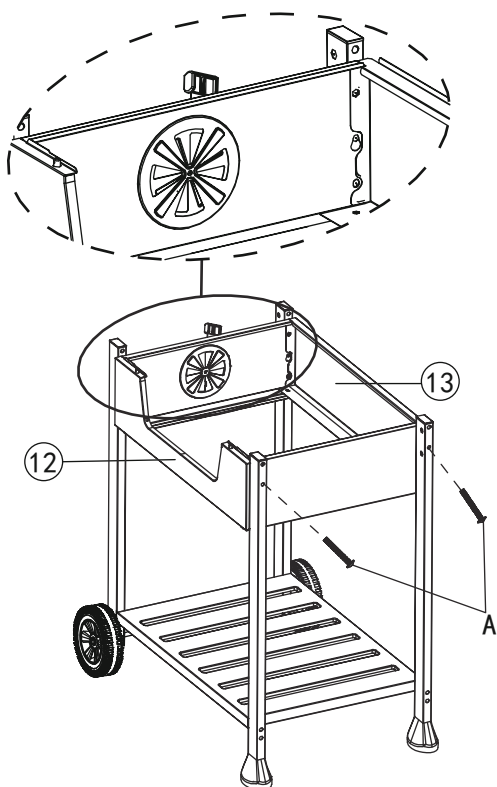

10 C ⊕  x4

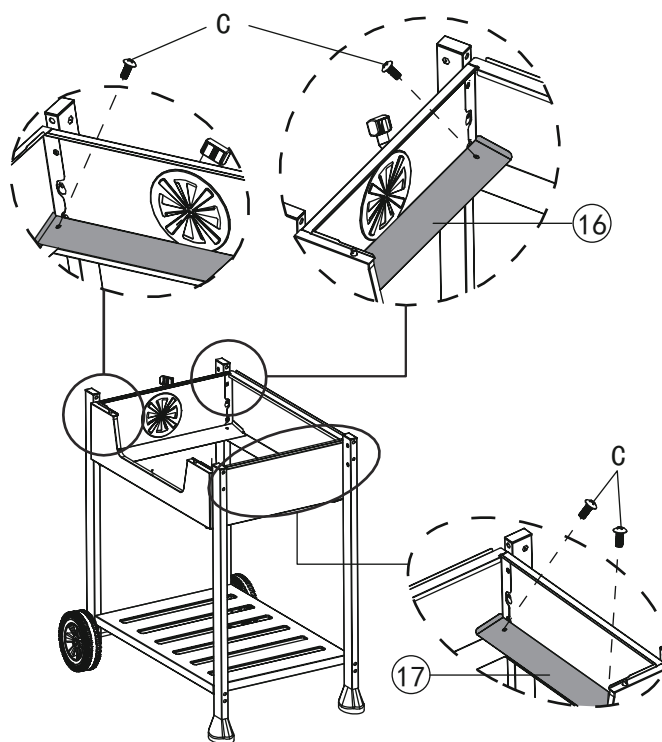

11

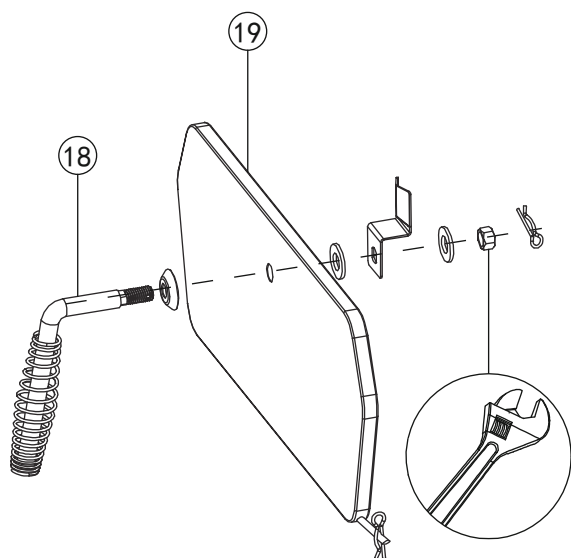

12

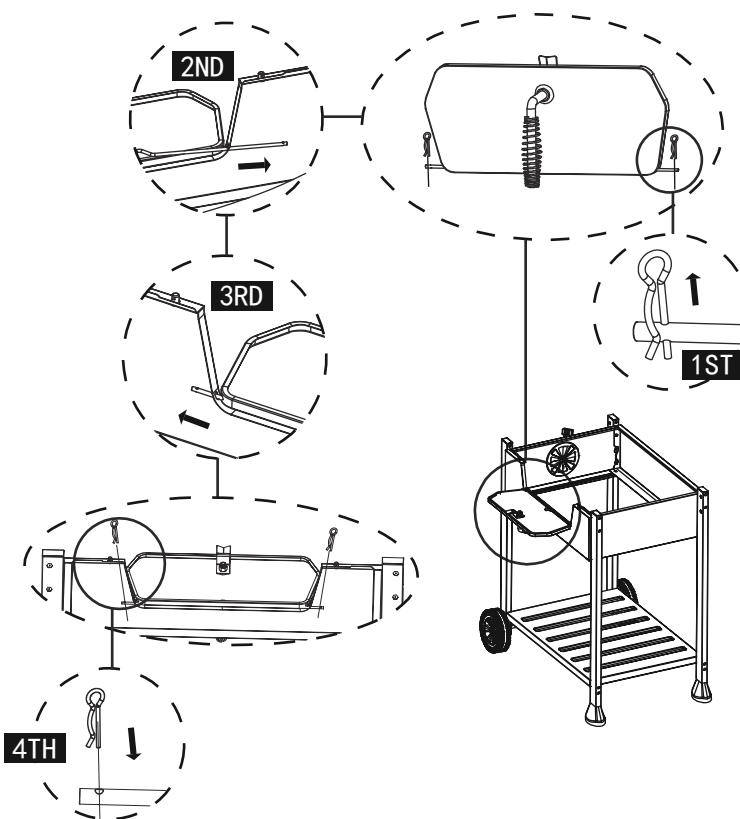

13 K  ×2

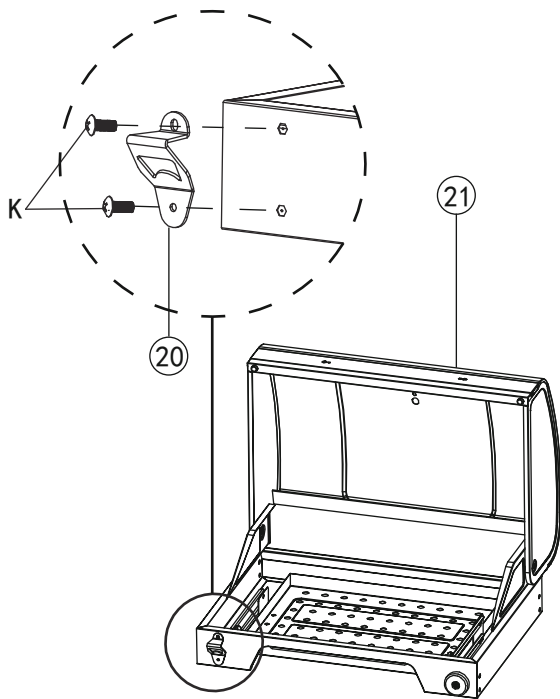

14

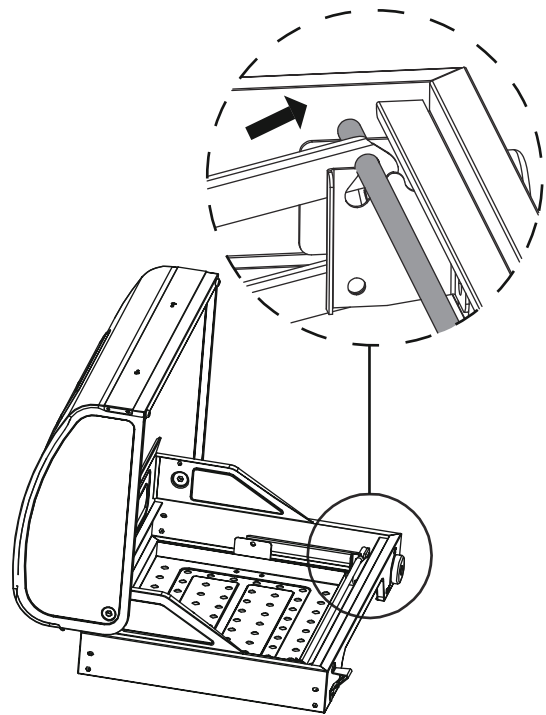

15 G  ×2

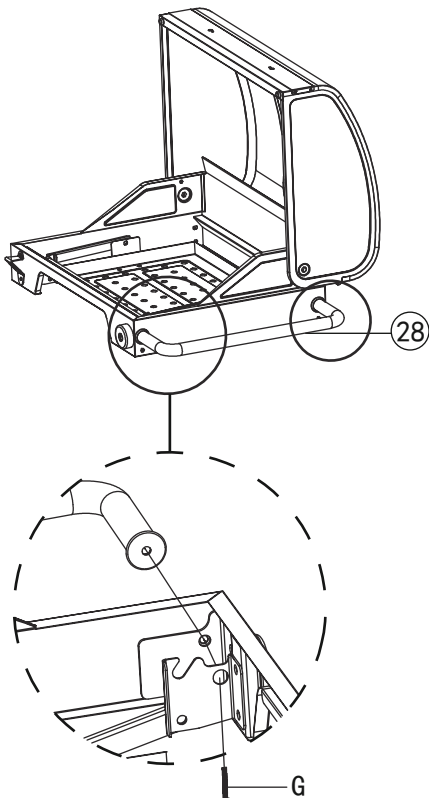

16

- Raise charcoal pan higher so as to secure crank.
- Heben Sie die Holzkohlepfanne höher an, um die Kurbel zu sichern.
- Relevez d'abord le bac à charbon, puis fixez la manivelle.

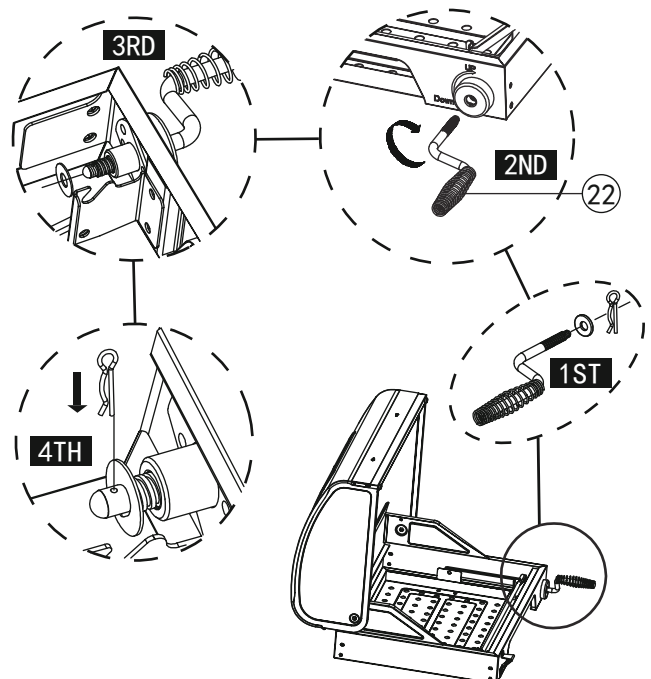

17

- Turn the crank to adjust the height of charcoal pan as needed.
- Die Holzkohle Pfanne kann, wie nötig, auf die Höhe eingestellt werden.
- Le bac à charbon peut être ajusté à la hauteur selon vos besoins.

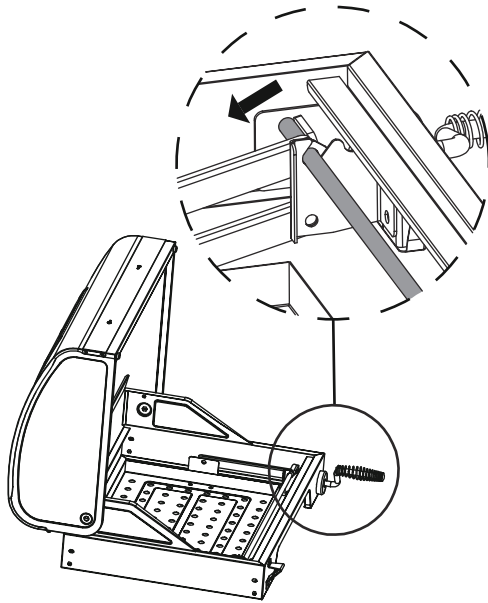

18

A ⊕ ↘ ×4



1ST

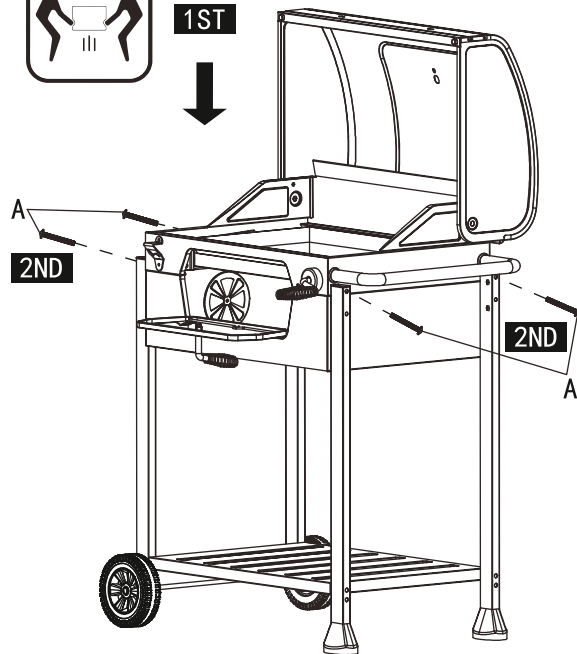

19

G ⊕ ↘ ×2

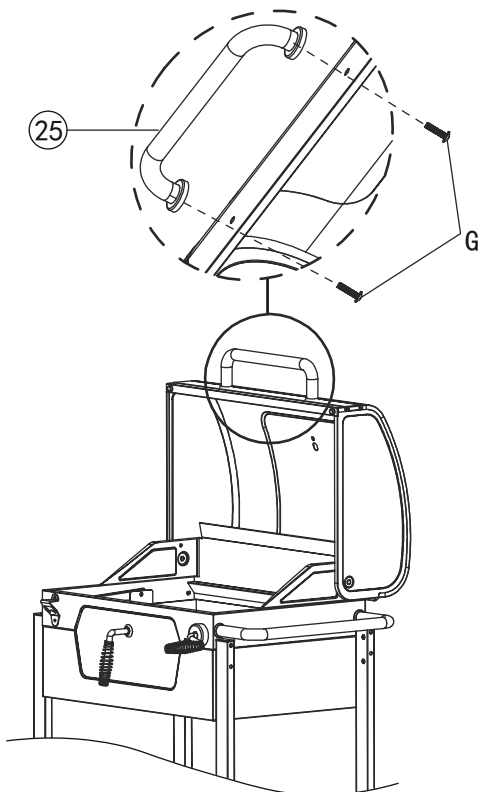

20

G ⊕ ↘ ×2  
F ⊕ ⊙ ×2

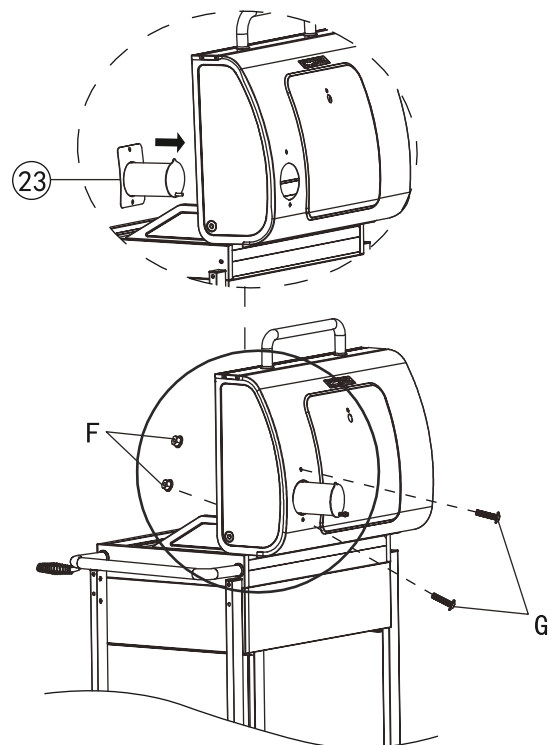

21

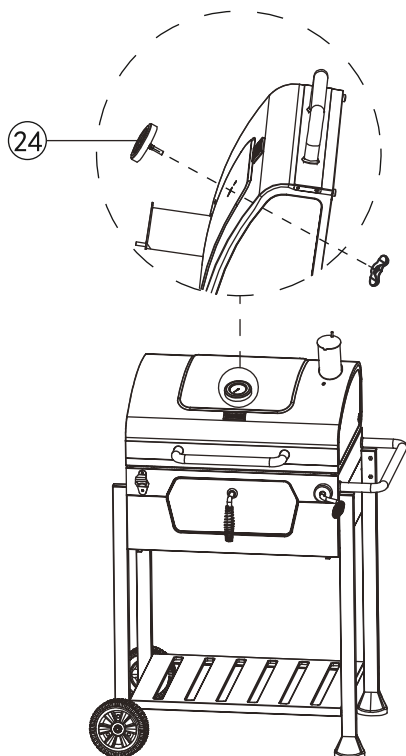

22

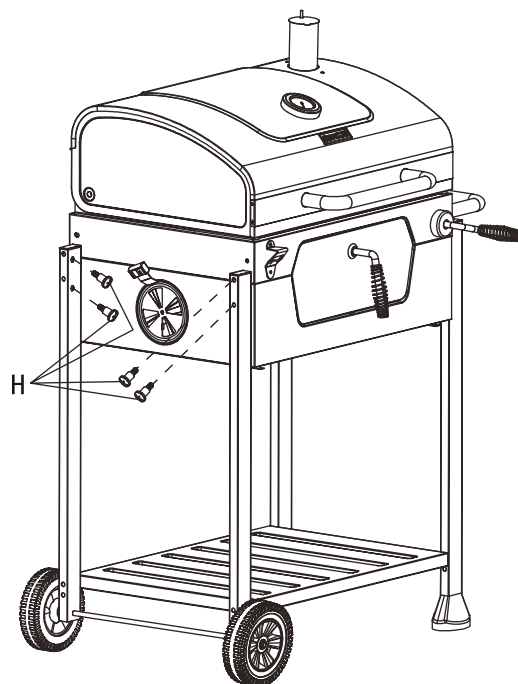
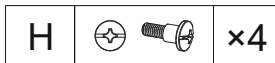

23

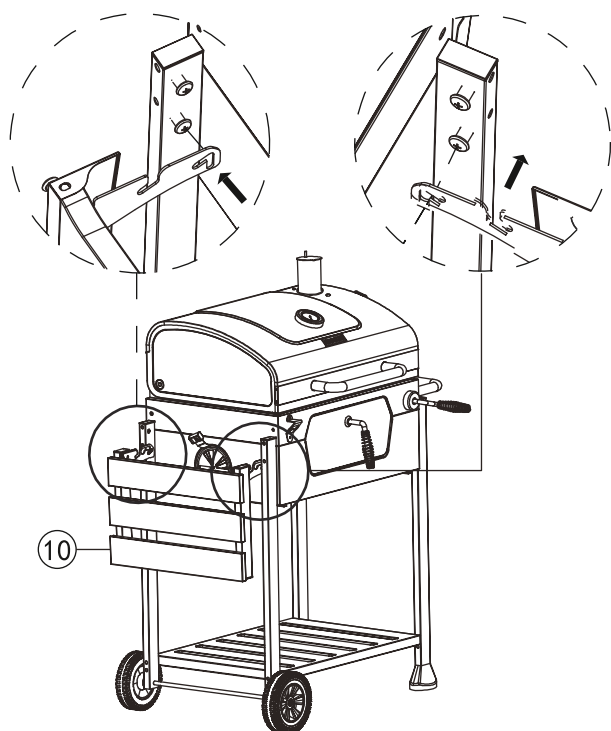

24

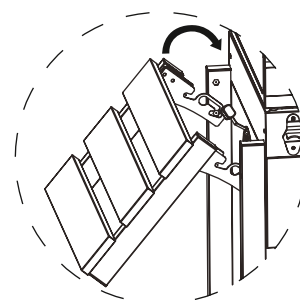

- Foldable side table.
- Klappbarer Beistelltisch.
- Tables d'appoint pliable.

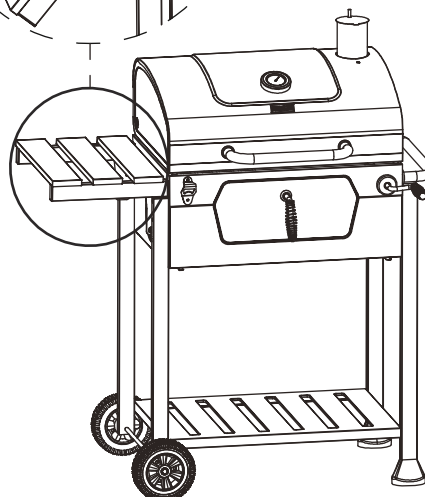

25

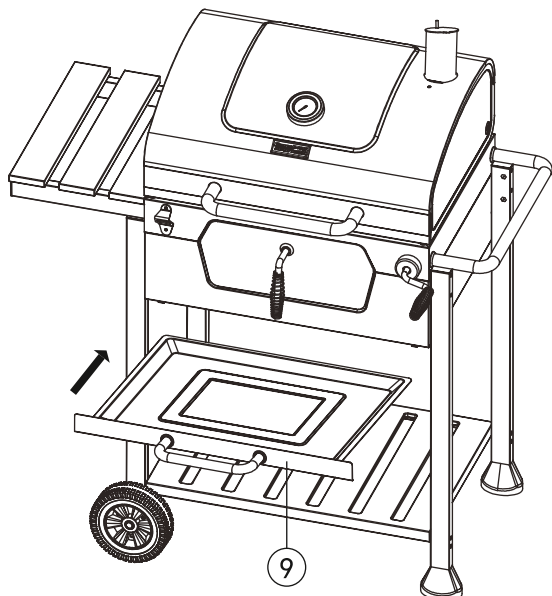

26

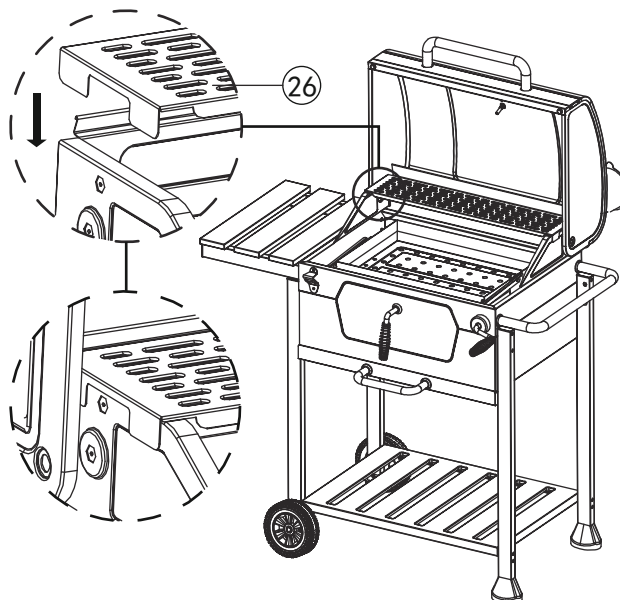

27

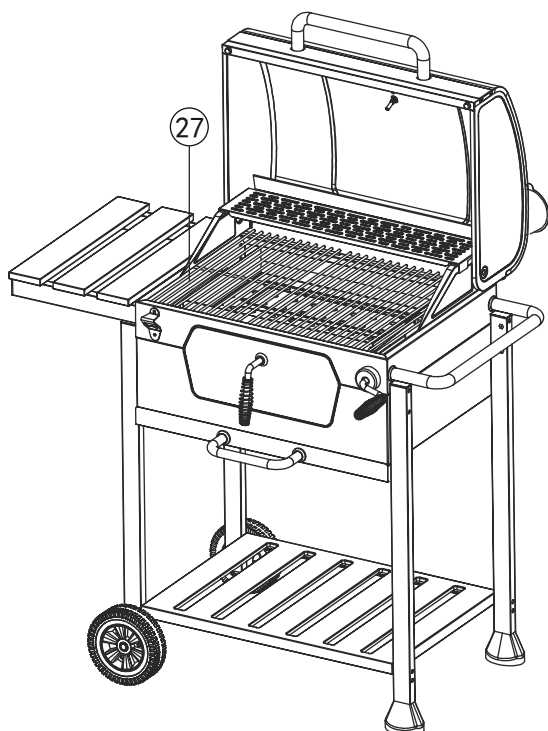

### Manufacturer's information:

 Ningbo Huige Outdoor Products Co., Ltd.

 No.333 Tianhai Road, Binhai Industrial Zone, Fenghua District, Ningbo, China

 [info@huigeoutdoor.com](mailto:info@huigeoutdoor.com)

 <https://www.huigeoutdoor.com/contact/>

### Herstellerinformationen:

 Ningbo Huige Outdoor Products Co., Ltd.

 Nr.333 Tianhai Straße, Binhai Industrielle Zone, Fenghua Distrikt, Provinz Zhejiang, China

 [info@huigeoutdoor.com](mailto:info@huigeoutdoor.com)

 <https://www.huigeoutdoor.com/contact/>

### Information du fabricant:

 Ningbo Huige Outdoor Products Co., Ltd.

 No.333 Tianhai Rue, Binhai Industrial, ZoneFenghua District, Zhejiang Province, Chine

 [info@huigeoutdoor.com](mailto:info@huigeoutdoor.com)

 <https://www.huigeoutdoor.com/contact/>

# **Thank You For Choosing Us.**

**Vielen Dank, dass Sie sich für uns entschieden haben.  
Merci de nous avoir choisis.**

# **Any Problem! We Can Help**

**Jedes Problem! Wir können helfen!  
Toutes les questions! Nous pouvons vous aider!**

**Customer Service  
Kundendienst  
Service de Clientèle**

**0800-00 60088**

**Monday to Friday  
(8:30 am - 5:00 pm CET)**

**Montag - Freitag  
(8:30 AM - 5:00 PM, CET)**

**Du lundi au vendredi,  
de 8 h 30 à 17 h 00, CET**

**[service@royalgourmeteu.com](mailto:service@royalgourmeteu.com)**